

1. MARK OUT THE OUTSIDE FACE OF COLUMNS (OVERALL FOOTPRINT OF CARPORT)
2. CHECK DIAGONAL DISTANCE OF OVERALL FOOTPRINT IS EQUAL (PURPLE LINES)
3. MARK OUT CENTRELINE OF FOOTING BRACKET (GREEN LINES) ENSURE DIRECTION OF VEHICLE APPROACH CORRECT
4. CHECK DIAGONAL DISTANCE BETWEEN FOOTING BRACKET SETOUT IS EQUAL (BLUE LINES)
5. FIX FOOTING BRACKETS TO SLAB AT INTERSECTION OF FOOTING BRACKET SETOUT, REFER TO ENG'S DRAWING FOR FIXING DETAILS

- NOTE:
1. COLUMNS CAN ALSO BE SETOUT ON THE FOUR CORNERS OF THE CARPORT
 2. COLUMNS CAN ALSO BE SET INTO CONCRETE FOOTINGS, ADDITIONAL ENGINEERING DETAIL WOULD BE REQUIRED

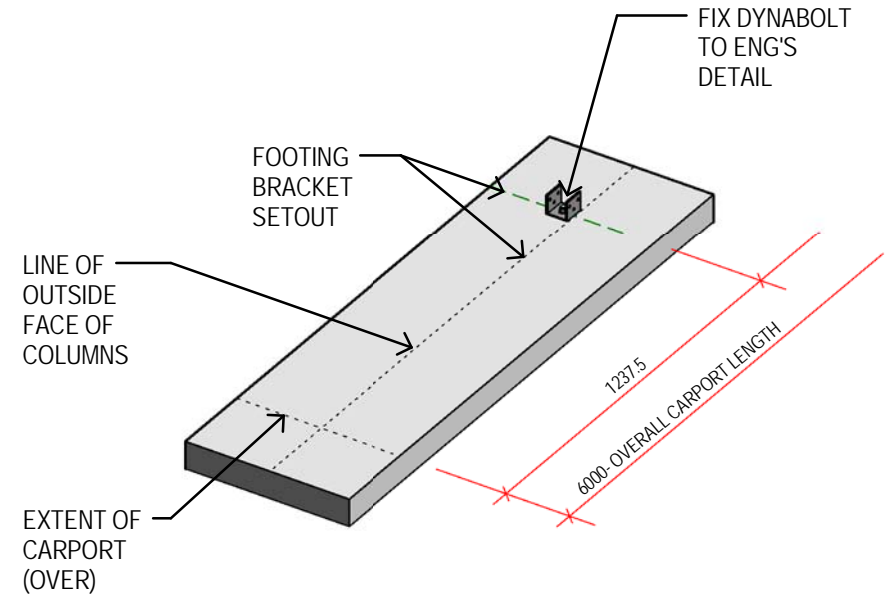
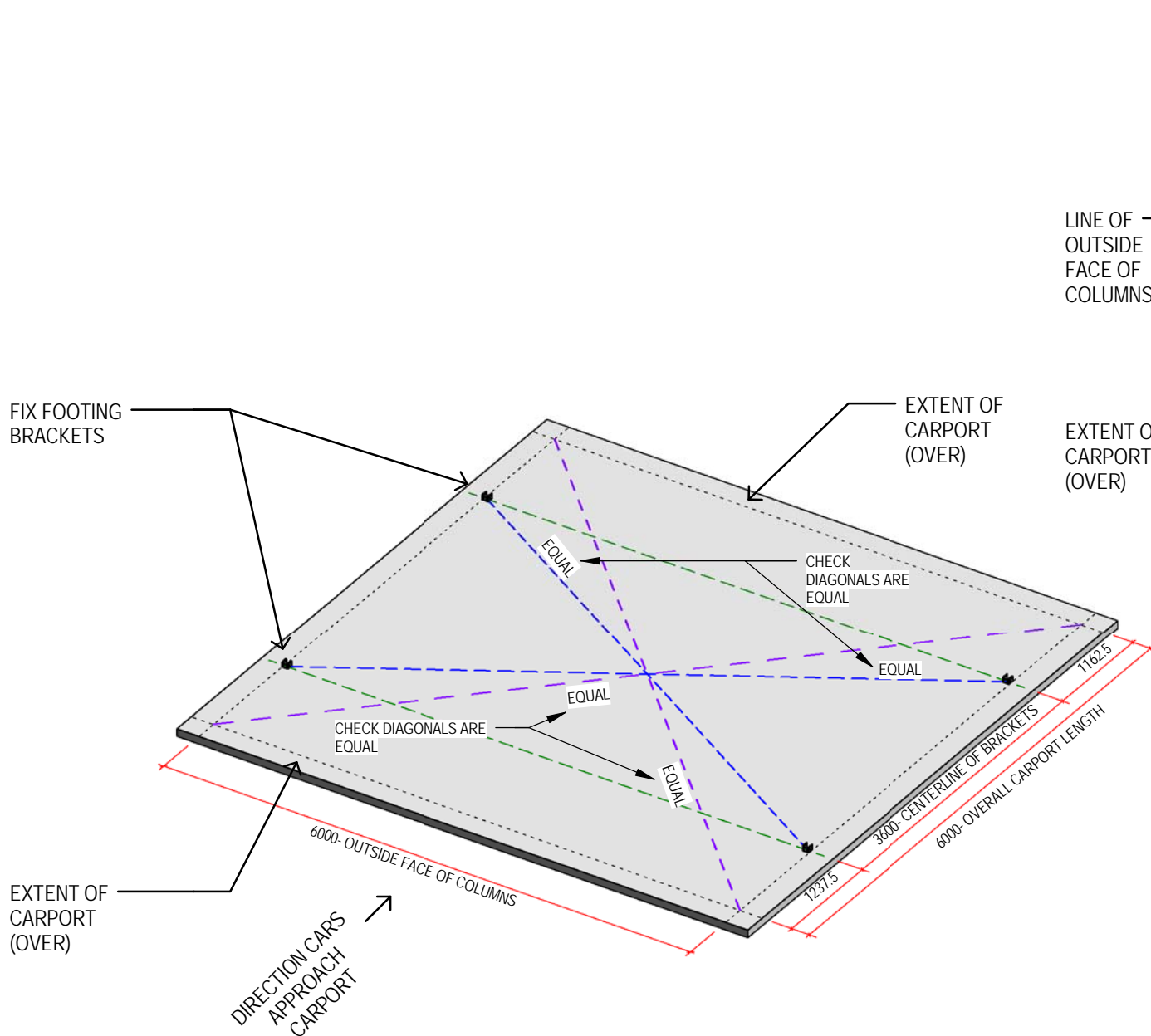

Steeline
HUNTER
29 Firebrick Drive, Thornton NSW 2322
PO Box 309 Thornton NSW 2322
Ph: 02 4966 3030 Fx: 02 4966 3334
hunteradmin@steeline.com.au
ABN: 56 120 570 989

CARPORT STEP 1

1. FIX CARPORT BRACKETS TO TOP OF POSTS
2. FIX COLUMNS OVER FOOTING BRACKETS
3. SUPPORT WITH TEMPORARY BRACING (NOT PROVIDED)
4. ENSURE COLUMNS ARE VERTICAL, USE 1200 LONG SPIRIT LEVEL TO CHECK
5. FIX BASE OF COLUMN TO FOOTING BRACKET

- NOTE:
1. COLUMN HEIGHT CAN BE VARIED TO SUIT
 2. 125 HEIGHT DIFFERENCE FOR COLUMNS FOR CURRENT LAYOUT
 3. 170 HEIGHT DIFFERENCE FOR COLUMNS ON CORNERS OF CARPORT

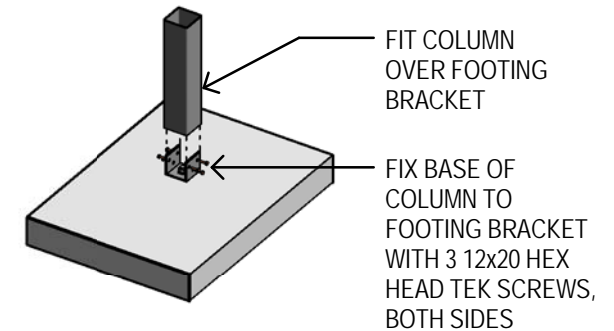
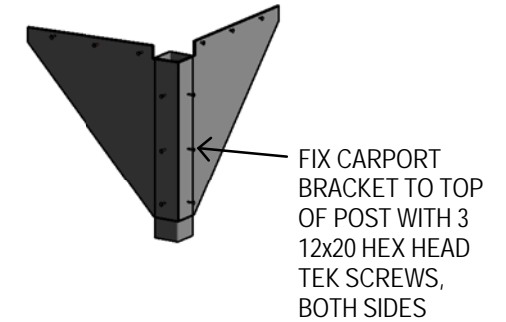
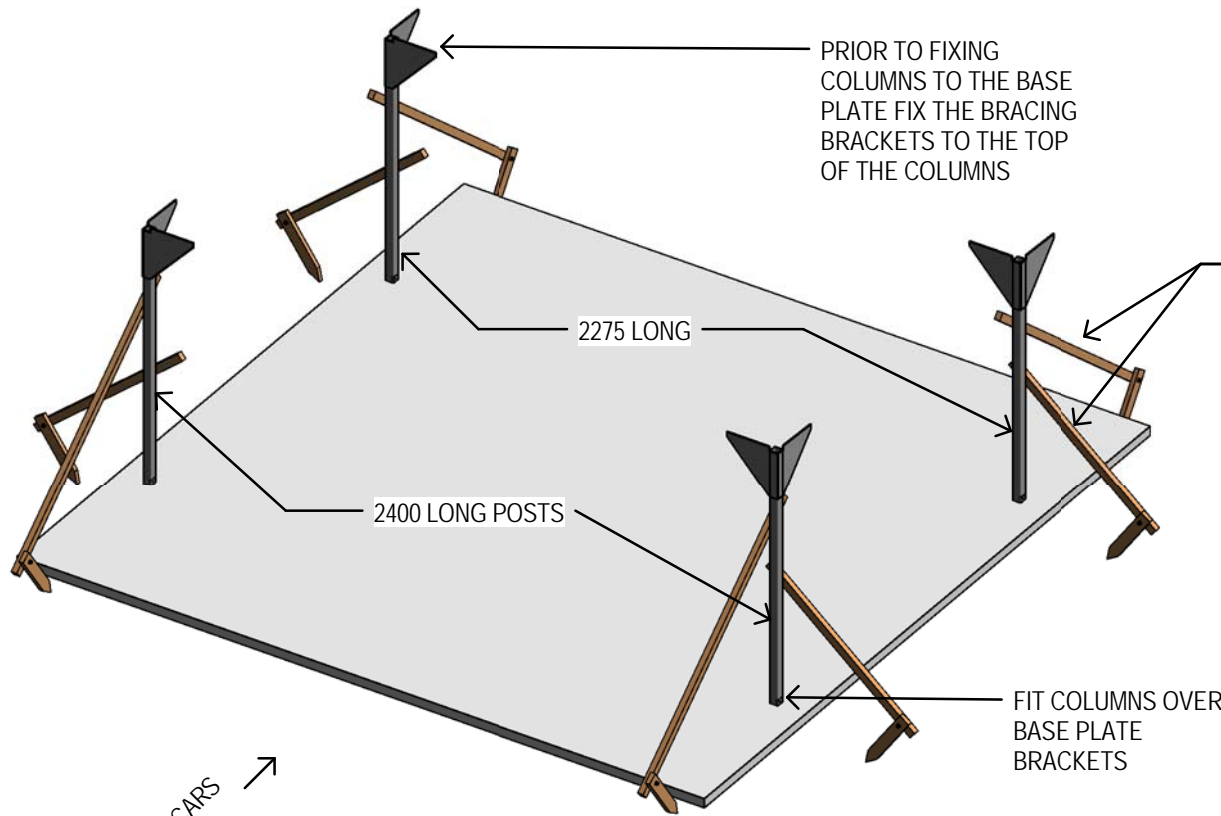

DIRECTION CARS
APPROACH
CARPORT →

Steeline
HUNTER
29 Firebrick Drive, Thornton NSW 2322
PO Box 309 Thornton NSW 2322
Ph: 02 4966 3030 Fx: 02 4966 3334
hunteradmin@steeline.com.au
ABN: 56 120 570 989

CARPORT STEP 2

1. LIFT LIPLESS PURLINS INTO POSITION (MULTIPLE PERSON LIFT)
2. ENSURE DISTANCE FROM CARPORT BRACKETS TO ENDS OF PURLINS ARE EQUAL ON FOUR CORNERS
3. FIX PURLINS TO CARPORT BRACKETS

ENSURE CENTRELINE OF PRE-PUNCHED HOLE IN LIPLESS PURLIN IS 37.5 FROM BRACING BRACKET

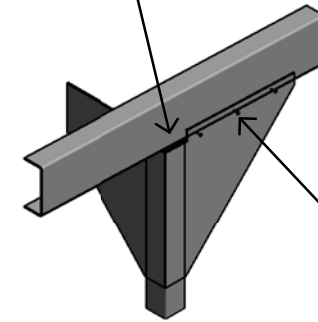

FIX CARPORT BRACKET TO SIDE OF RAFTER WITH 3 12x20 HEX HEAD TEK SCREWS

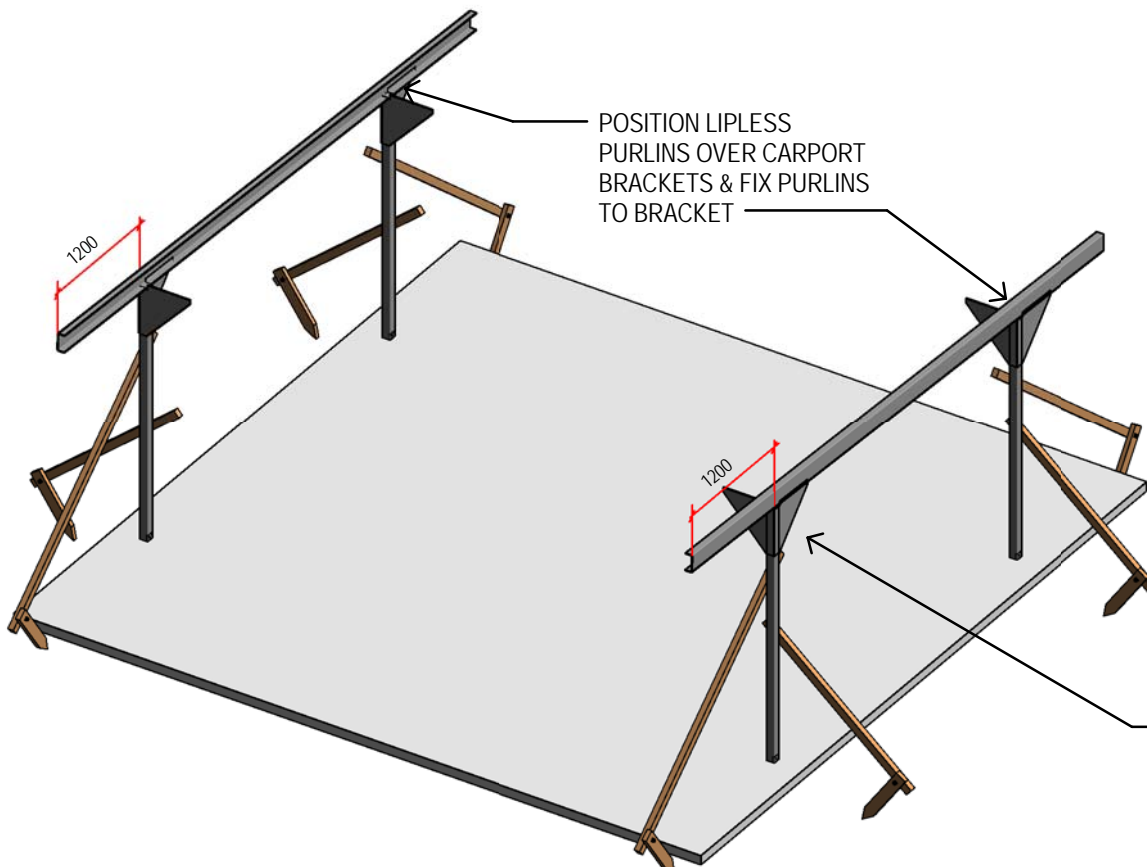

POSITION LIPLESS PURLINS OVER CARPORT BRACKETS & FIX PURLINS TO BRACKET

FIT END OF LIPLESS PURLIN 1200 FROM BRACING BRACKET



29 Firebrick Drive, Thornton NSW 2322
 PO Box 309 Thornton NSW 2322
 Ph: 02 4966 3030 Fx: 02 4966 3334
 hunteradmin@steeline.com.au
 ABN: 56 120 570 989

CARPORT STEP 3

1. FIT BOTH PURLINS OVER COLUMNS, FIX PURLINS TO CARPORT BRACKET (MULTIPLE PERSON LIFT)
2. FIX BOTH END PURLINS (MULTIPLE PERSON LIFT)
3. FIX INTERNAL PURLINS (MULTIPLE PERSON LIFT)

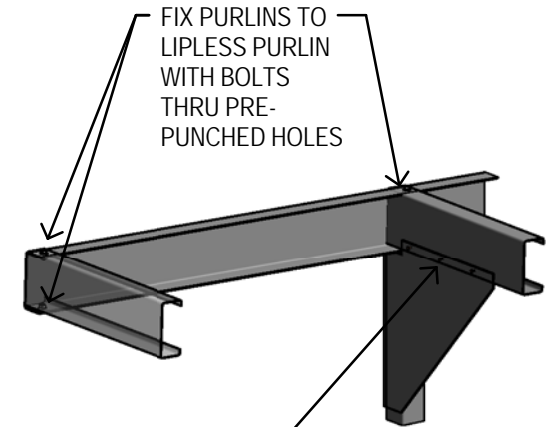
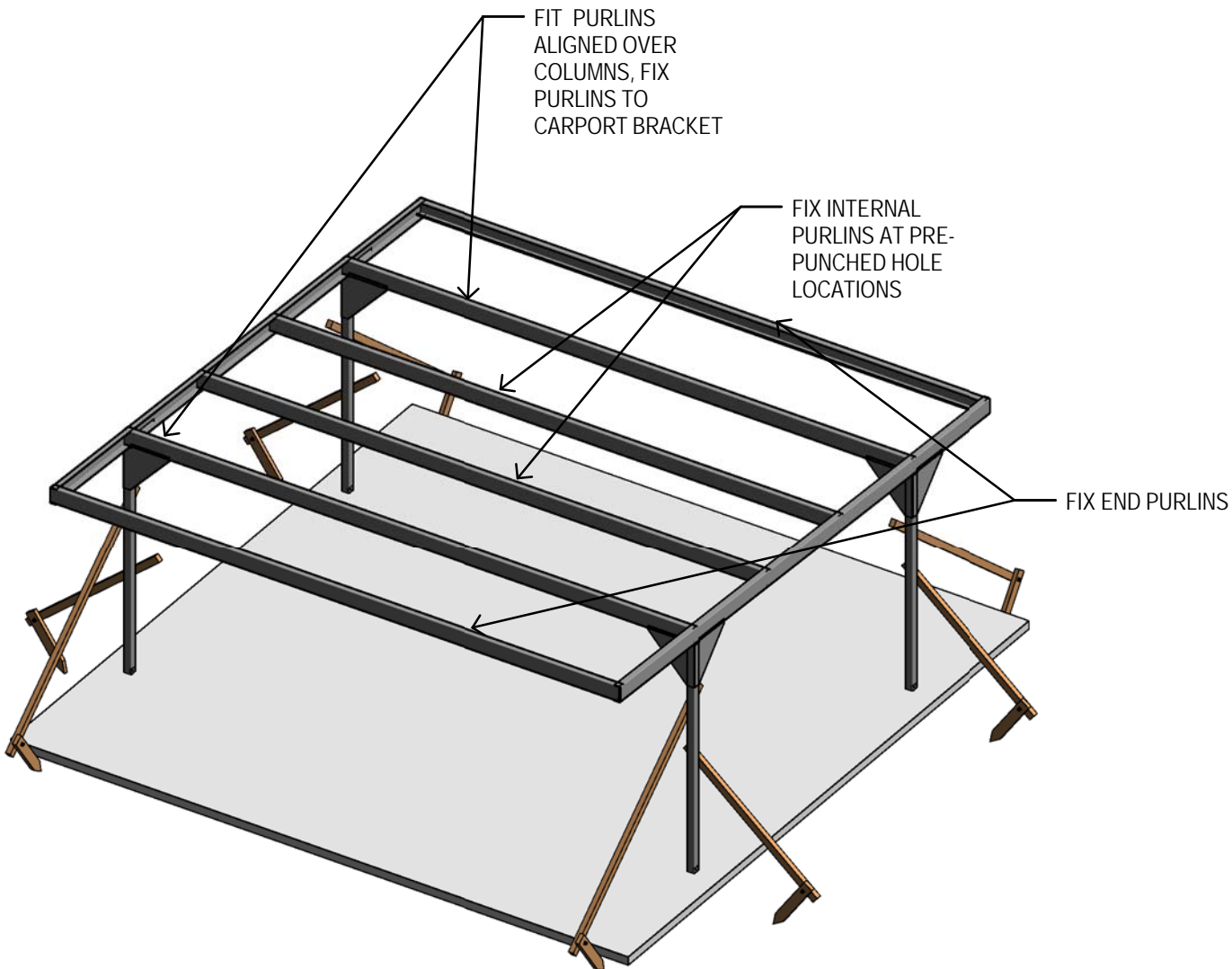

FIX CARPORT BRACKET TO SIDE OF PURLIN WITH 3 12x20 HEX HEAD TEK SCREWS

Steeline
HUNTER
29 Firebrick Drive, Thornton NSW 2322
PO Box 309 Thornton NSW 2322
Ph: 02 4966 3030 Fx: 02 4966 3334
hunteradmin@steeline.com.au
ABN: 56 120 570 989

CARPORT STEP 4

1. FIX STOP END PLATES TO INT. BRACKETS PRIOR TO FIXING IN PLACE
2. FIX INT. BRACKETS CENTRALLY TO RAFTERS

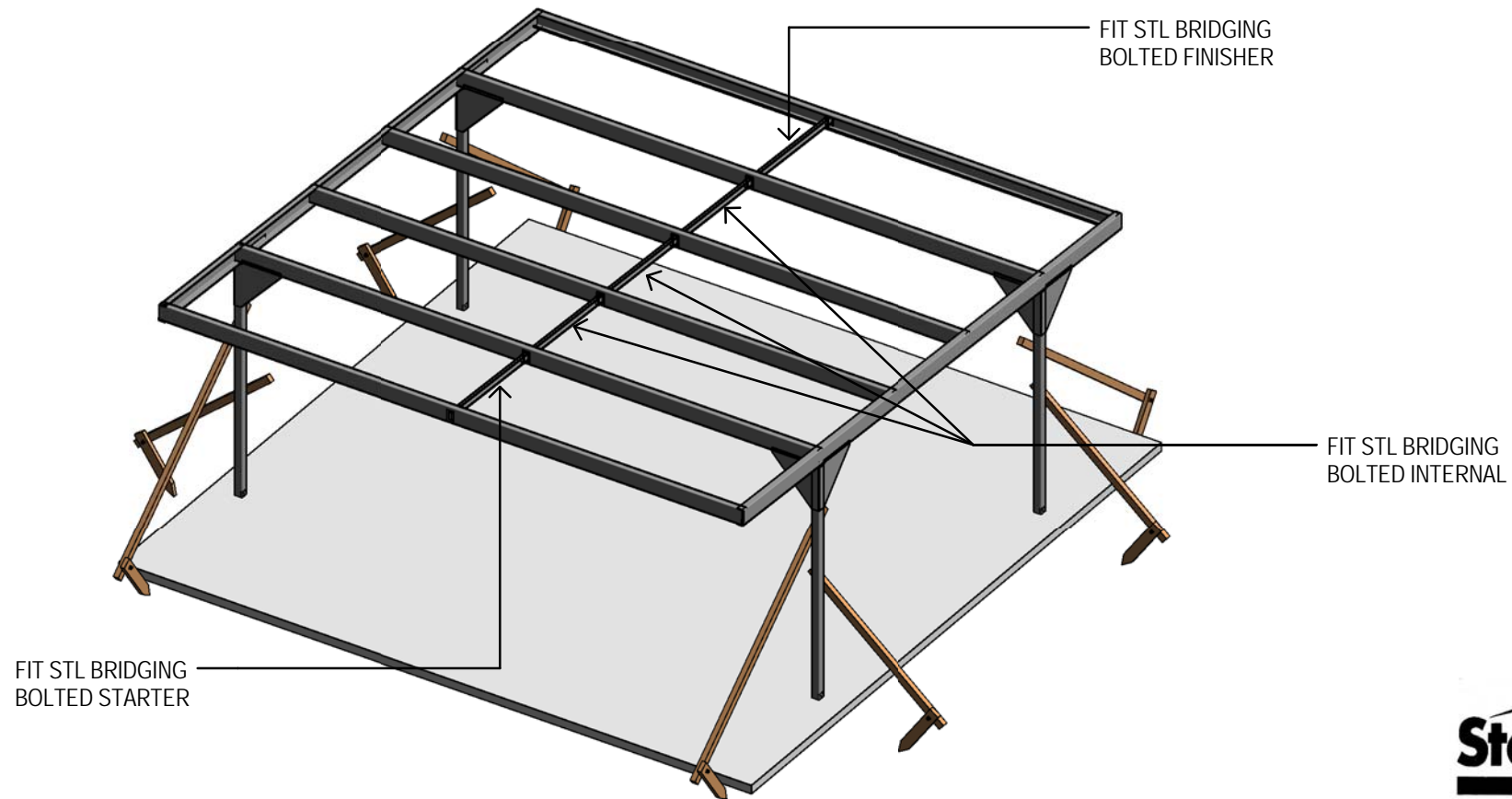

Steeline
HUNTER
29 Firebrick Drive, Thornton NSW 2322
PO Box 309 Thornton NSW 2322
Ph: 02 4966 3030 Fx: 02 4966 3334
hunteradmin@steeline.com.au
ABN: 56 120 570 989

CARPORT STEP 5

1. CHECK ROOF FRAMING DIAGONAL DISTANCES ARE EQUAL
2. FIT DIAGONAL BUILDERS STRAP BRACING (FIX END OF STRAP BRACING ONLY)
3. FIT BUILDERS STRAP TENSIONER
4. RE-CHECK DIAGONAL DISTANCES ARE EQUAL

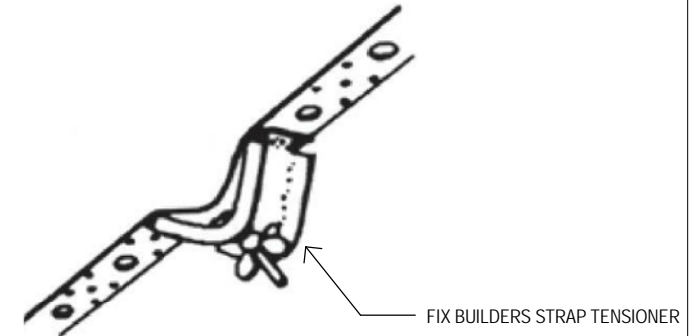
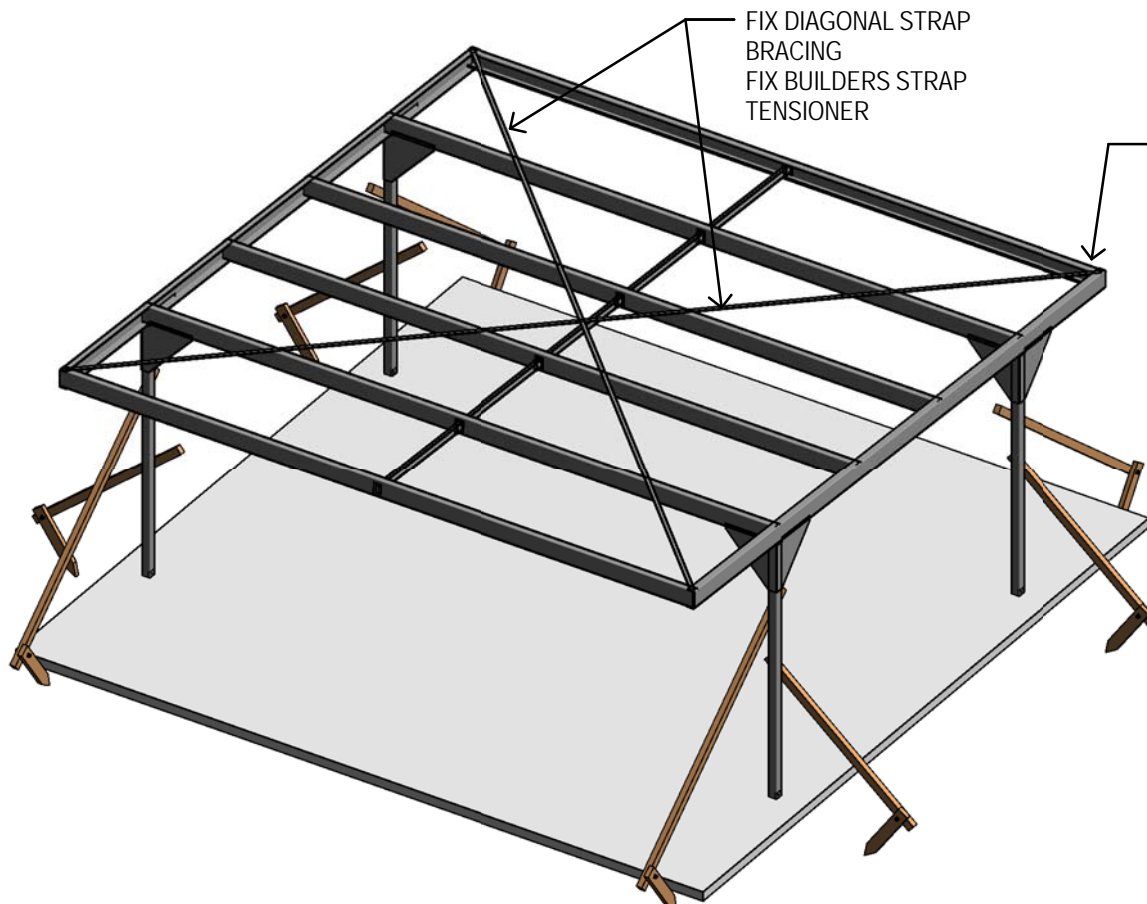
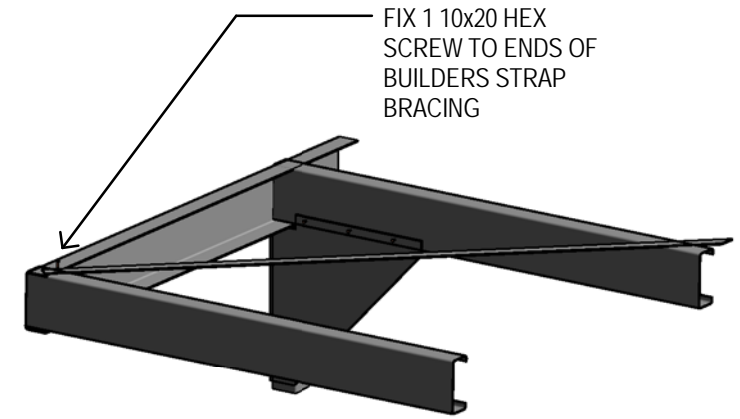

Steeline
HUNTER

29 Firebrick Drive, Thornton NSW 2322
PO Box 309 Thornton NSW 2322
Ph: 02 4966 3030 Fx: 02 4966 3334
hunteradmin@steeline.com.au
ABN: 56 120 570 989

CARPORT STEP 6

1. FIX FIRST ROOF SHEET ALIGNED PARALLEL WITH EDGE
2. ENSURE BOTTOM OF ROOF SHEET OVERHANG PURLIN BY 50mm
3. FIX ROOF SHEET WITH M6x50mm SCREWS WITH SEALS AT EVERY RIB (EXCLUDING EDGES OF ROOF FRAMING)
4. FIX FOLLOWING SHEETS OVER RIB ON PREVIOUS SHEET
5. FIT LAST SHEET TO ALLOW LAPS TO ALIGN AND SHEET TO NOT OVERHANG ROOF FRAME
6. REMOVE TEMPORARY BRACING

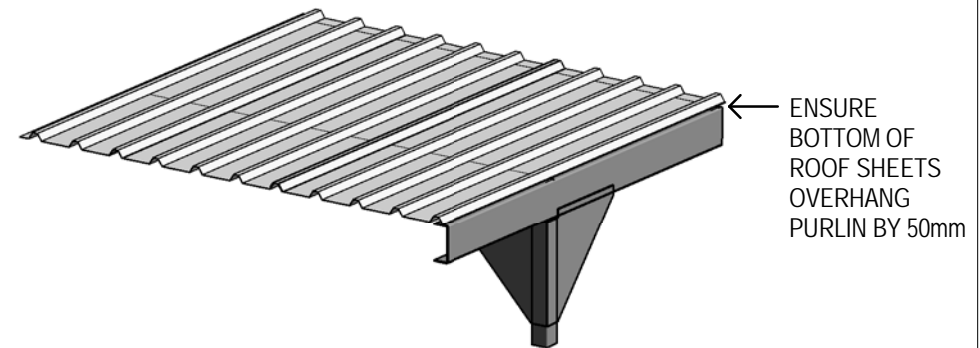
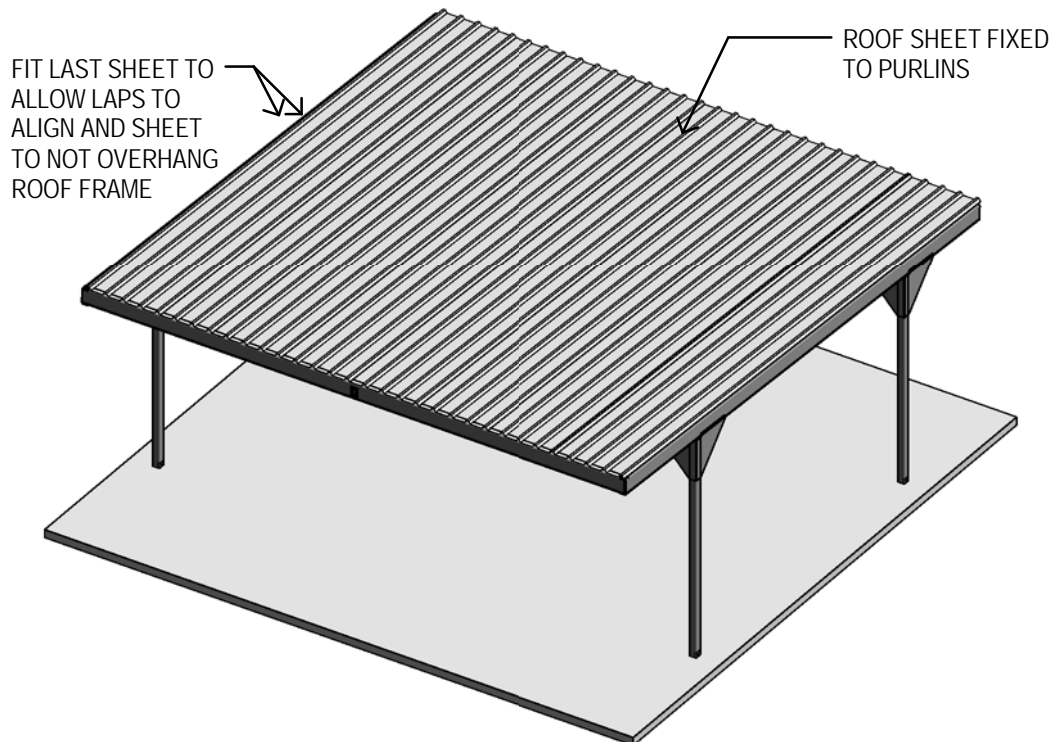
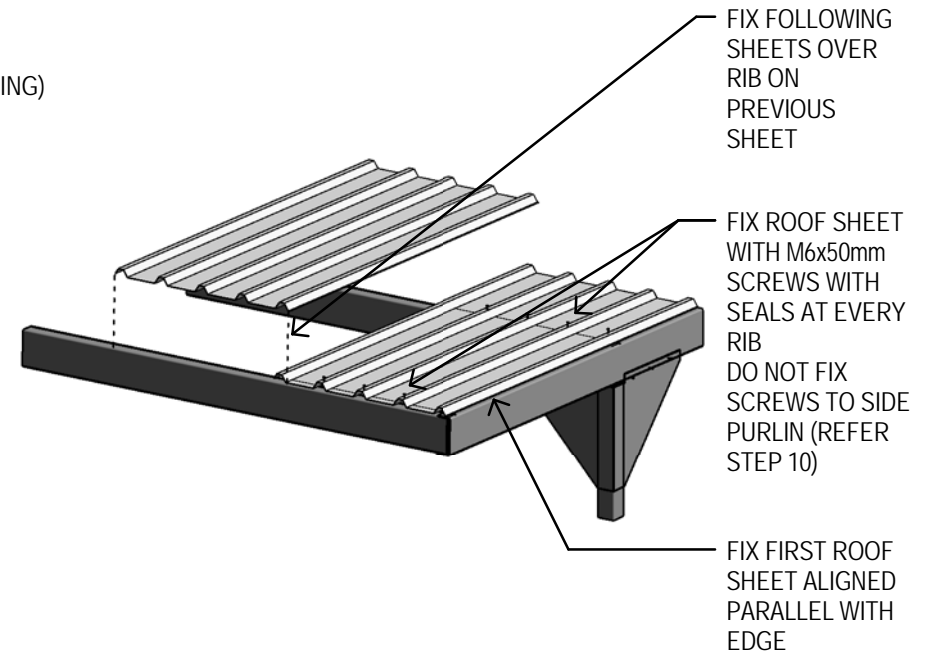

Steeline
HUNTER

29 Firebrick Drive, Thornton NSW 2322
PO Box 309 Thornton NSW 2322
Ph: 02 4966 3030 Fx: 02 4966 3334
hunteradmin@steeline.com.au
ABN: 56 120 570 989

CARPORT
STEP 7

1. FIX TRIMMED FASCIA TO 4 SIDES OF ROOF
2. TRIM BOTTOM PORTION OF TRIMMED FASCIA AT CARPORT BRACKET LOCATIONS
3. FIT FASCIA EXTERNAL CORNERS

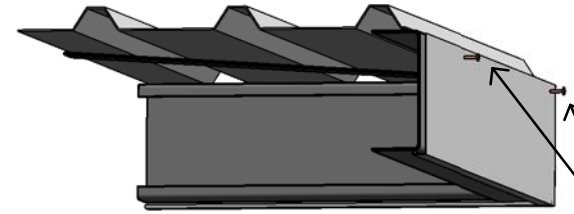

FIX TRIMMED FASCIA TO RAFTER WITH 12x20 HEX SCREWS @ 600cts

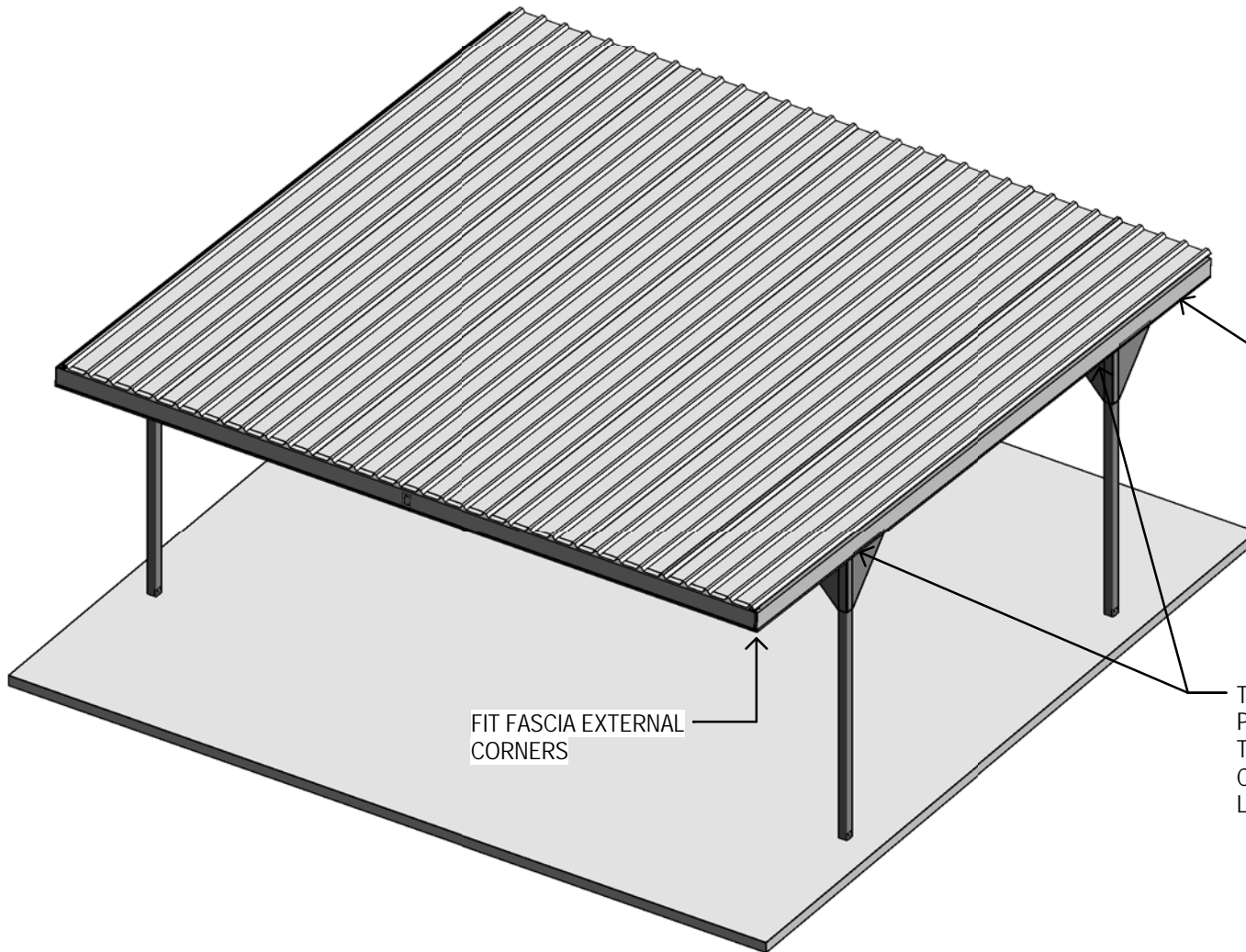

FIX TRIMMED FASCIA TO 4 SIDES OF ROOF FRAMING

TRIM BOTTOM PORTION OF TRIMMED FASCIA AT CARPORT BRACKET LOCATION

FIT FASCIA EXTERNAL CORNERS

Steeline
HUNTER
29 Firebrick Drive, Thornton NSW 2322
PO Box 309 Thornton NSW 2322
Ph: 02 4966 3030 Fx: 02 4966 3334
hunteradmin@steeline.com.au
ABN: 56 120 570 989

CARPORT STEP 8

1. FIX GUTTER BRACKETS TO ROOF SHEET
2. PRIOR TO FITTING GUTTER CUT 90mm HOLE IN BASE OF GUTTER
3. FIX GUTTER TO GUTTER BRACKETS
4. FIX UNI-DROP FITTING INTO HOLE & SEAL WITH SEALANT
5. FIX GUTTER END BRACKETS, SEAL BRACKETS TO GUTTER, FIX WITH TWO POP RIVETS

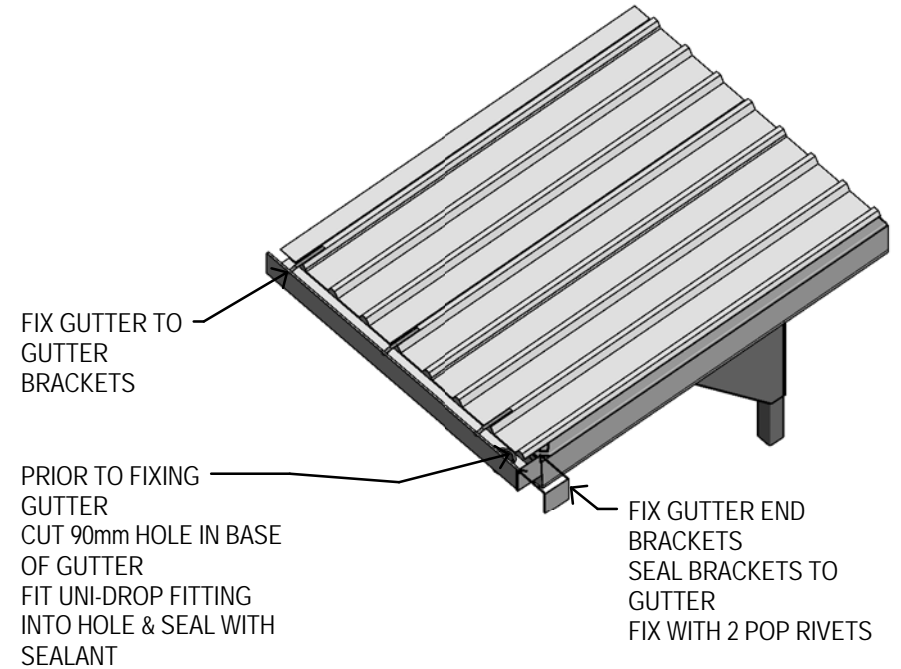
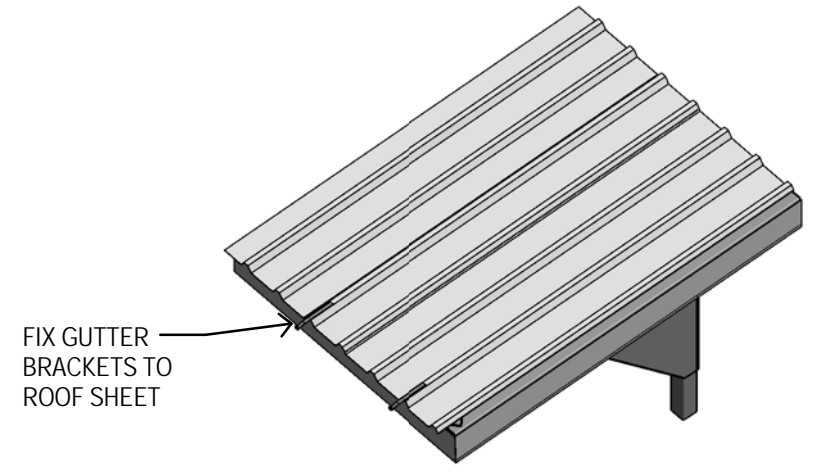
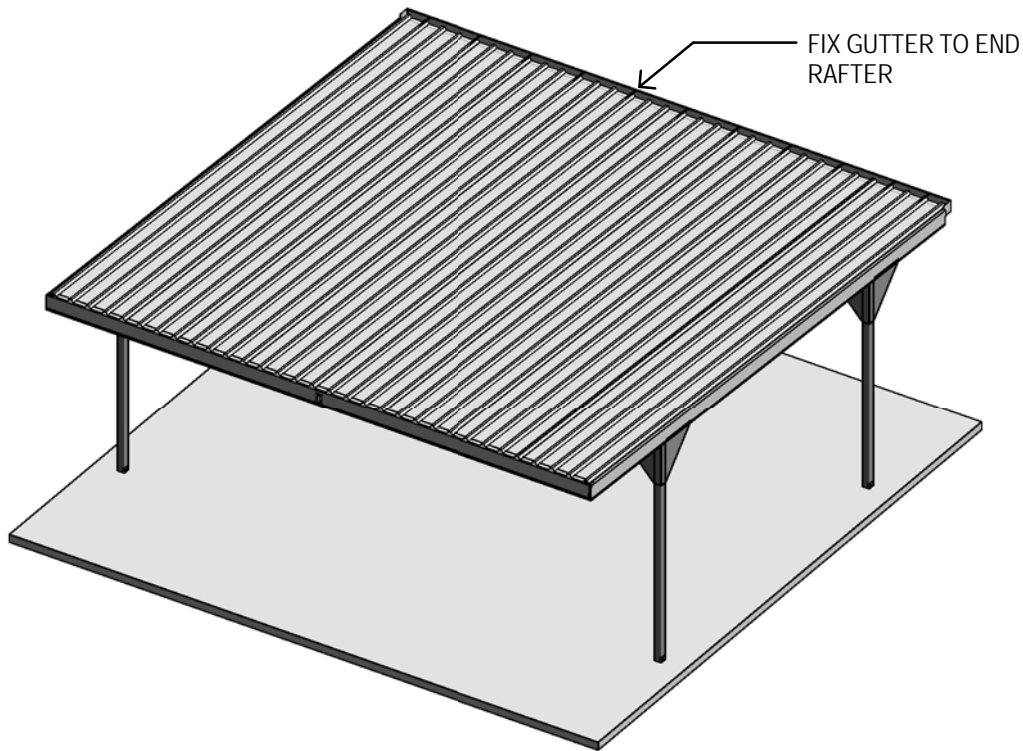

Steeline
HUNTER
29 Firebrick Drive, Thornton NSW 2322
PO Box 309 Thornton NSW 2322
Ph: 02 4966 3030 Fx: 02 4966 3334
hunteradmin@steeline.com.au
ABN: 56 120 570 989

CARPORT STEP 9

1. FIX SIDE BARGE CAPPINGS FIRST
2. FIX TOP BARGE CAPPING TO PURLINS
3. PRIOR TO FIXING TOP BARGE CAPPING, TRIM BARGE CAPPING TO SUIT SIDE BARGE CAPPINGS & ROOF SHEET PROFILE

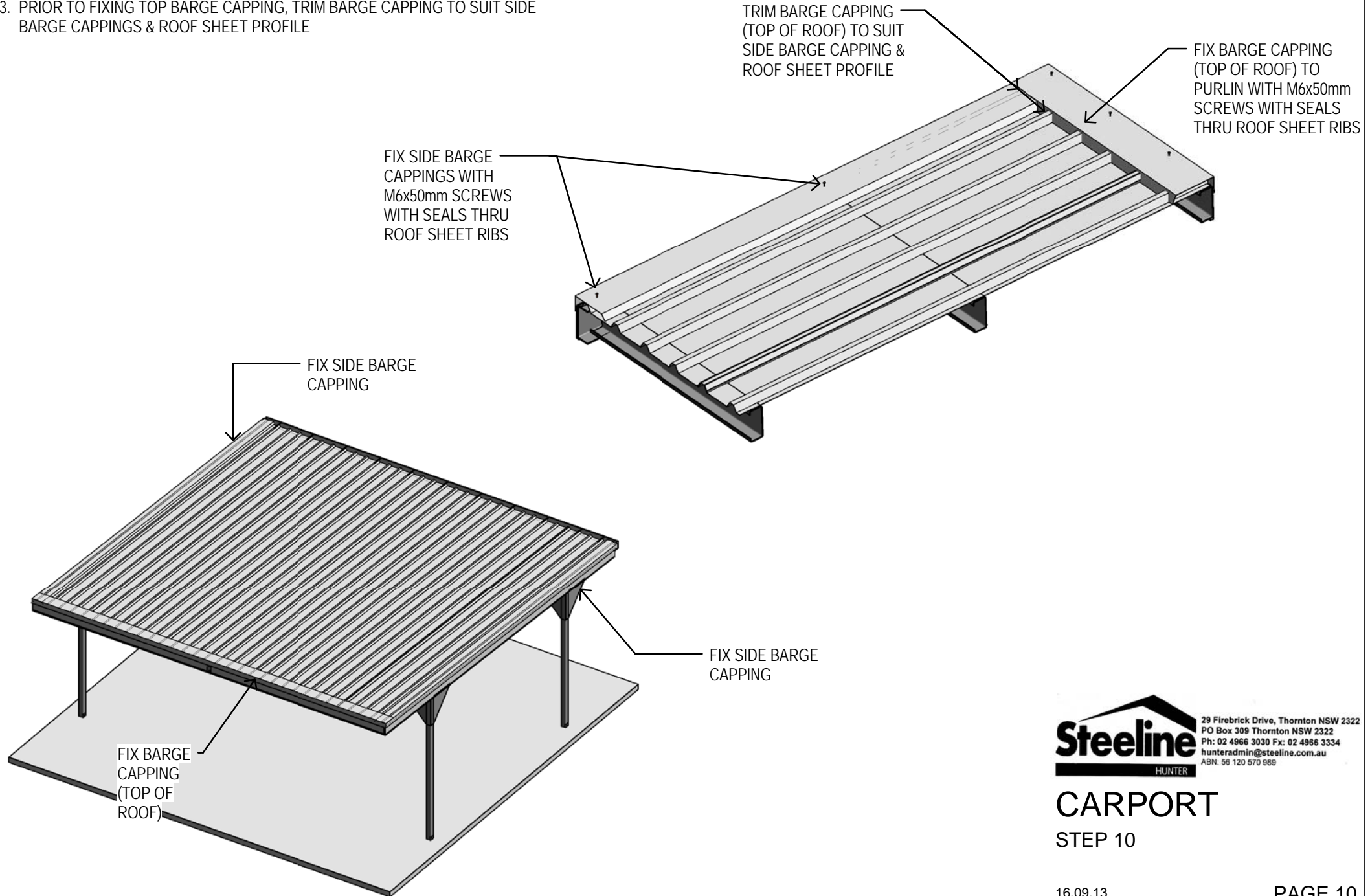

Steeline
HUNTER
29 Firebrick Drive, Thornton NSW 2322
PO Box 309 Thornton NSW 2322
Ph: 02 4966 3030 Fx: 02 4966 3334
hunteradmin@steeline.com.au
ABN: 56 120 570 989

CARPORT

STEP 10